

MH 2 Wash

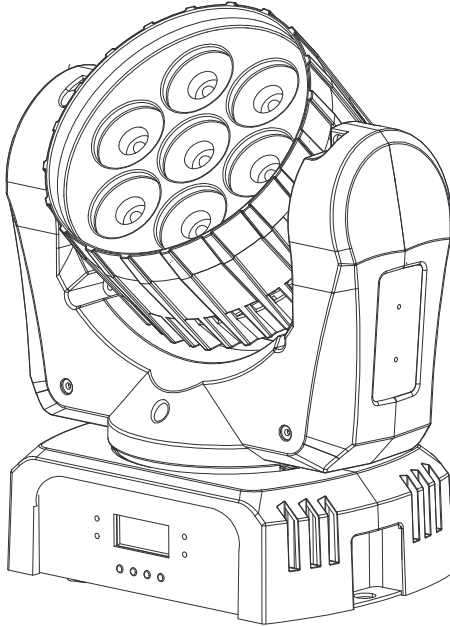

User Manual



© 2013-2015 Martin Professional ApS. Information subject to change without notice. Martin Professional and all affiliated companies disclaim liability for any injury, damage, direct or indirect loss, consequential or economic loss or any other loss occasioned by the use of, inability to use or reliance on the information contained in this manual. The RUSH logo, the Martin logo, the RUSH name, the Martin name and all other trademarks in this document pertaining to services or products by Martin Professional or its affiliates and subsidiaries are trademarks owned or licensed by Martin Professional or its affiliates or subsidiaries.

Martin Professional • Olof Palmes Allé 18 • 8200 Aarhus N • Denmark • www.martin.com

Manual: Revision G

Table of contents

| | |
|---|----|
| Safety information | 5 |
| Introduction | 10 |
| Before using the product for the first time | 10 |
| Physical installation | 11 |
| Fastening the fixture to a flat surface | 11 |
| Mounting the fixture on a truss | 11 |
| AC power | 13 |
| Linking fixtures to power in a chain | 14 |
| Fixture overview | 15 |
| Connections | 15 |
| Control data link | 16 |
| Tips for reliable data transmission | 16 |
| Connecting the data link | 16 |
| Fixture setup | 17 |
| Using the control menus | 17 |
| DMX addressing | 17 |
| Show Mode (stand-alone operation) | 18 |
| Sound activation in Show Mode | 18 |
| Dimming curves | 19 |
| Pan/tilt inversion | 19 |
| Backlight | 20 |
| White balance adjustment | 20 |
| Function delay | 20 |
| DMX State – automatic Show Mode startup | 21 |
| Manual test | 21 |
| Auto test | 21 |
| Temperature | 21 |
| Fixture time | 22 |
| Firmware version | 22 |
| Pro defaults | 22 |
| Reset | 22 |
| Head home position (offsets) adjustment | 22 |
| DMX control of fixture settings | 23 |
| Effects | 24 |
| Pan and tilt | 24 |
| Strobe effects | 24 |
| Electronic dimming | 24 |
| Color control | 24 |
| Maintenance | 25 |
| Cleaning | 25 |

| | |
|---------------------------------|----|
| Replacing the primary fuse..... | 26 |
| Service and repairs | 26 |
| DMX protocol | 27 |
| Control menus..... | 30 |
| Troubleshooting | 32 |
| Specifications | 34 |

Safety information



WARNING!

Read the safety precautions in this manual before installing, operating or servicing this product.

The following symbols are used to identify important safety information on the product and in this manual:



Warning!

Safety hazard. Risk of severe injury or death.



Warning!

Powerful light emission. Risk of eye injury.



Warning!

See user manual for important safety information.



Warning!

Hazardous voltage. Risk of lethal or severe electric shock.



Warning!

Hot surfaces and fire hazard.



Warning! Risk Group 1 product according to EN 62471. Do not stare directly into the beam. Do not view the light output with optical instruments or any device that may concentrate the beam.

This lighting fixture is for professional use only and must be installed by a qualified technician. It is not for household use. It presents risks of severe injury or death due to fire hazards, electric shock and falls. It produces a powerful, concentrated beam of light that can create a fire hazard or a risk of eye injury if the safety precautions below are not followed.



Install, operate and service RUSH by Martin™ products only as directed in their user manuals, or you may create a safety hazard or cause damage that is not covered by product warranties. Follow the safety precautions listed below and observe all warnings in this manual and printed on the product. Keep this user manual for future use.

For the latest user documentation and other information about this and all Martin™ products, please visit the Martin website at <http://www.martin.com>

If you have any questions about how to install, operate or service the fixture safely, please contact your Martin™ distributor (see www.martin.com/distributors for details) or call the Martin™ 24-hour service hotline on +45 8740 0000, or in the USA on 1-888-tech-180.

Respect all locally applicable laws, codes and regulations when installing, operating or servicing the fixture.



Protection from electric shock

Do not expose the fixture to rain or moisture.

Disconnect the fixture from AC power before carrying out any installation or maintenance work and when the fixture is not in use.

Ensure that the fixture is electrically connected to ground (earth).

Use only a source of AC power that complies with local building and electrical codes and has both overload and ground-fault (earth-fault) protection.

Socket outlets or external power switches used to supply the fixture with power must be located near the fixture and easily accessible so that the fixture can easily be disconnected from power.

Replace defective fuses with ones of the specified type and rating only.

Isolate the fixture from power immediately if the power plug or any seal, cover, cable, or other component is damaged, defective, deformed, wet or showing signs of overheating. Do not reapply power until repairs have been completed

Before using the fixture, check that all power distribution equipment and cables are in perfect condition and rated for the electrical requirements of all connected devices.

Use only Neutrik PowerCon cable connectors to connect to power sockets.

Do not connect devices to power in a chain that will exceed the electrical ratings of any cable or connector used in the chain.

The supplied power input cable is rated 6 A and can safely supply only one fixture with mains power. Do not connect any device to the fixture's MAINS OUT connector when using this cable. If you replace this cable and also use the replacement

cable to supply only one fixture with mains power, the replacement cable must also be rated 6 A minimum, have three conductors 18 AWG or 0.75 mm² minimum conductor size, have an outer cable diameter of 6 - 15 mm (0.2 - 0.6 in.) and be temperature-rated to suit the application. In the USA and Canada the cable must be UL listed, type SJT or equivalent. In the EU the cable must be type H05VV-F or equivalent.

To connect fixtures to mains power in a chain, you must first obtain 14 AWG or 1.5 mm² power input and throughput cables that are 16 A rated and temperature-rated to suit the application. In the USA and Canada the cables must be UL-listed, type SJT or equivalent. In the EU the cables must be type H05VV-F or equivalent. Suitable cables with Neutrik PowerCon connectors are available from Martin™ (see 'Accessories' on page 36). If you use these cables, you can connect fixtures to power in a linked chain, MAINS OUT throughput socket to MAINS IN input socket, but do not link more than:

- six (6) RUSH MH 2 fixtures in total at 100-120 V, or
- twelve (12) RUSH MH 2 fixtures in total at 200-240 V.

The voltage and frequency at the MAINS OUT socket are the same as the voltage and frequency applied to the MAINS IN socket. Only connect devices to the MAINS OUT socket that accept this voltage and frequency.



Protection from burns and fire

Do not operate the fixture if the ambient temperature (T_a) exceeds 40° C (104° F).

The surface of the product casing can reach up to 85° C (185° F) during operation. Avoid contact by persons and materials. Allow the fixture to cool for at least 10 minutes before handling.

Keep flammable materials well away from the fixture. Keep all combustible materials (e.g. fabric, wood, paper) at least 100 mm (4 in.) away from the fixture head.

Ensure that there is free and unobstructed airflow around the fixture. Provide a minimum clearance of 100 mm (4 in.) around fans and air vents.

Do not illuminate surfaces within 200 mm (7.9 ins.) of the fixture.

Do not attempt to bypass thermostatic switches or fuses.

Connect only other fixtures of the same type to the power throughput sockets. Do not connect any other type of device to these sockets.

Do not stick filters, masks or other materials onto any optical component.

The fixture's optical components can focus the sun's rays inside the fixture, creating a risk of fire and damage. Do not expose the front of the fixture to sunlight or any other bright light source.



Protection from eye injury

Do not stare directly into the product's light output.

Do not look at the light output with magnifiers, telescopes, binoculars or similar optical instruments that may concentrate the light output.

Ensure that persons are not looking directly into the LEDs when the product lights up suddenly. This can happen when power is applied, when the product receives a DMX signal, or when certain control menu items are selected.

To minimize the risk of eye irritation or injury, disconnect the fixture from power at all times when the fixture is not in use, and provide well-lit conditions to reduce the pupil diameter of anyone working on or near the fixture.



Protection from injury

Fasten the fixture securely to a fixed surface or structure when in use. The fixture is not portable when installed.

Ensure that any supporting structure and/or hardware used can hold at least 10 times the weight of all the devices they support.

If suspending from a rigging structure, fasten the fixture to a rigging clamp. Do not use safety cables as the primary means of support.

If the fixture is installed in a location where it may cause injury or damage if it falls, install as directed in this manual a secondary attachment such as a safety cable that will hold the fixture if a primary attachment fails. The secondary attachment must be approved by an official body such as TÜV as a safety attachment for the weight that it secures, must comply with EN 60598-2-17 Section 17.6.6 and must be capable of bearing a

static suspended load that is ten times the weight of the fixture and all installed accessories.

Allow enough clearance around the head to ensure that it cannot collide with an object or another fixture when it moves.

Check that all external covers and rigging hardware are securely fastened.

Block access below the work area and work from a stable platform whenever installing, servicing or moving the fixture.

Do not operate the fixture with missing or damaged covers, shields or any optical component.

Do not lift or carry the fixture by its head. Support the fixture by its base only.

In the event of an operating problem, stop using the fixture immediately and disconnect it from power. Do not attempt to use a fixture that is obviously damaged.

Do not modify the fixture in any way not described in this manual or install other than genuine RUSH by Martin™ parts.

Refer any service operation not described in this manual to a qualified technician.

Introduction

The MH 2 Wash is a compact, fast and powerful LED moving head wash effect incorporating seven 10 W long-life LEDs with full RGBW color mixing and a range of color presets. It provides smooth electronic dimming as well as strobe effects. The fixture is rugged, lightweight and compact, and is ideal for mobile DJs, touring or small fixed installations.

The fixture can be controlled using any DMX-compliant controller or operated as a standalone device running pre-programmed shows with the option of 'music trig' sound activation.

The fixture is supplied with this user manual and a 1.5 m (5 ft.) power cable (local power plug not included).

Before using the product for the first time

1. Read 'Safety information' on page 5 before installing, operating or servicing the fixture.
2. Unpack and ensure that there is no transportation damage before using the fixture. Do not attempt to operate a damaged fixture.
3. If the fixture is not going to be hard-wired to a mains supply, install a local power plug (not supplied) to the end of the supplied power cable.
4. Before operating, ensure that the voltage and frequency of the power supply match the power requirements of the fixture.
5. Check the RUSH support pages on the Martin Professional website at www.martin.com for the most recent user documentation and technical information about the fixture. RUSH by Martin™ user manual revisions are identified by the revision letter at the bottom of the inside cover.

Note that whenever AC power is applied to the fixture, it will reset all effects and functions to their home positions. Be prepared for the fixture head to move. A reset usually takes around 20 seconds.

Physical installation



Warning! Read 'Safety information' on page 5 before installing the fixture.

The fixture is designed for indoor use only and must be used in a dry location with adequate ventilation. Ensure that none of the fixture's ventilation slots are blocked and ensure that the product is firmly fastened to a secure surface or rigging structure.

Martin™ can supply safety cables and rigging clamps that are suitable for use with the fixture (see 'Accessories' on page 36).

Fastening the fixture to a flat surface

The fixture can be fastened to a hard, fixed, flat surface. Ensure that the surface and all fasteners used can support at least 10 times the weight of all fixtures and equipment they will support.

Fasten the fixture securely. Do not stand it on a surface or leave it where it can be moved or fall over. If you install the fixture in a location where it may cause injury or damage if it falls, secure it as directed below with a securely anchored safety cable that will hold the fixture if the primary fastening method fails.

Mounting the fixture on a truss

The fixture can be clamped to a truss or similar rigging structure hanging vertically downwards only. Use an open-type clamp such as a G-clamp or a half-coupler clamp (see illustration on right).



To clamp the fixture to a truss:

1. Check that the rigging structure can support at least 10 times the weight of all fixtures and equipment to be installed on it.
2. Block access under the work area.
3. The fixture is supplied with a bracket to which a rigging clamp can be attached. Bolt a rigging clamp securely to the bracket. The bolt used must be M12, grade 8.8 steel minimum, and fastened with a self-locking nut.

4. Fasten the bracket to the fixture by screwing the two Allen bolts provided fully into holes **A** in the base of the fixture (see illustration on right) using the washers provided or suitable lock washers.

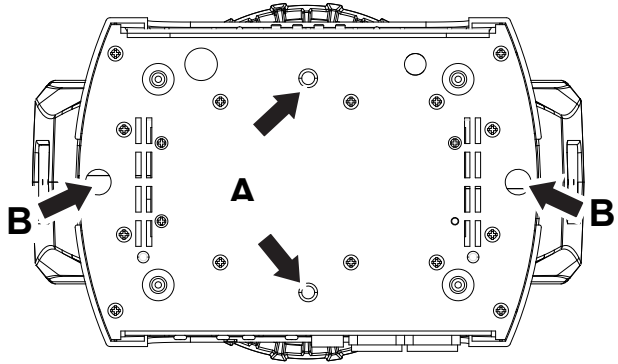

5. Working from a stable platform, hang the fixture on the truss (see illustration below) and fasten the rigging clamp onto the truss so that the fixture is suspended securely.
6. Secure the fixture with a safety cable as directed below.
7. Check that the head will not collide with other fixtures or objects.

Securing with a safety cable

Secure the fixture with a safety cable (or other secondary attachment) that is approved for the weight of the fixture so that the safety cable will hold the fixture if the primary attachment fails. Loop the safety cable through one of the two attachment points **B** in the base of the fixture base (see illustration above) and around a secure anchoring point.

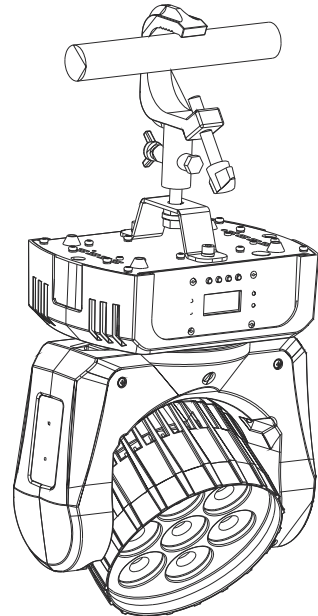

AC power



Warning! Read ‘Safety information’ on page 5 before connecting the fixture to AC mains power.



Warning! The mains power input cable supplied with the fixture is rated 6 A and can supply only one fixture with mains power. Do not connect any device to the fixture’s MAINS OUT power throughput socket when using this input cable. If you want to connect other fixtures to the MAINS OUT socket, see ‘Linking fixtures to power in a chain’ on page 14.

For protection from electric shock, the fixture must be grounded (earthed). The power distribution circuit must be equipped with a fuse or circuit breaker and ground-fault (earth-fault) protection.

Socket outlets or external power switches used to supply the fixture with power must be located near the fixture and easily accessible so that the fixtures can easily be disconnected from power.

Do not insert or remove live Neutrik PowerCon connectors to apply or cut power, as this may cause arcing at the terminals that will damage the connectors.

Do not use an external dimming system to supply power to the fixture, as this may cause damage to the fixture that is not covered by the product warranty.

The fixture can be hard-wired to a building electrical installation if you want to install it permanently, or a power plug (not supplied) that is suitable for the local power outlets can be installed on the power cable.

If you install a power plug on the power cable, install a grounding type (earthed) plug with integral cable grip that is rated minimum 250 V, 6 A. Follow the plug manufacturer’s instructions and connect the wires in the power cable as shown in this table:

| | Live or L | Neutral or N | Earth, Ground or Ⓧ |
|------------------|------------------|---------------------|---------------------------|
| US system | Black | White | Green |
| EU system | Brown | Blue | Yellow/green |

The fixture has an auto-ranging power supply that accepts AC mains power at 100-240 V at 50/60 Hz. Do not apply AC mains power at any other voltage or frequency to the fixture.

Linking fixtures to power in a chain

If you obtain a 14 AWG / 1.5 mm² power input cable and 14 AWG / 1.5 mm² throughput cables from Martin™ (see 'Accessories' on page 36), you can relay mains power from one fixture to another by connecting fixtures to power in a linked daisy-chain, MAINS OUT throughput socket to MAINS IN input socket, Using 14 AWG or 1.5 mm² cables from Martin™, you can link:

- Maximum six (6) RUSH MH 2 fixtures in total at 100-120 V, or
- Maximum twelve (12) RUSH MH 2 fixtures in total at 200-240 V.

If you install a power plug on the 14 AWG / 1.5 mm² power cable, install a grounding type (earthed) plug with integral cable grip that is rated minimum 250 V, 16 A.

Fixture overview

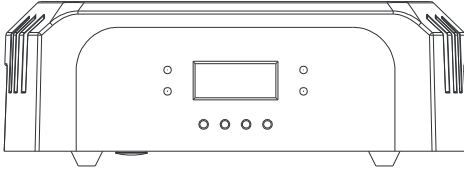

LEDs

The two LEDs on the front of the base give the following indications:

| | | |
|-------|----------|-------------------------------|
| DMX | On | Valid DMX input received |
| SOUND | Flashing | Sound activation (music trig) |

Buttons

The buttons below the display panel have the following functions:

| | |
|-------|--|
| MENU | <ul style="list-style-type: none">• Activate the menu mode functions, or• Return to the previous level of the menu structure, or• Hold to exit the menus |
| DOWN | Go down a menu branch |
| UP | Go up a menu branch |
| ENTER | Confirm the selected function |

Press and hold the MENU button to exit the menus (the fixture exits automatically after 60 seconds when there has been no user input).

Connections

The rear of the base has a blue Neutrik PowerCon socket for MAINS IN and a light-grey Neutrik PowerCon socket for MAINS OUT (thru) connections. There are also 3-pin and 5-pin XLR sockets for DMX data IN and OUT (thru).

Fuse

The T 6.3 A primary fuse F1 is located in a fuseholder next to the MAINS IN and OUT sockets.

Control data link

A DMX 512 data link is required in order to control the fixture via DMX. The fixture has 3-pin and 5-pin XLR connectors for DMX data input and output.

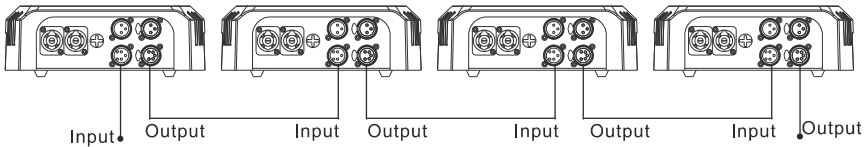

The number of daisy-chained fixtures is limited by the number of DMX channels required by the fixtures in relation to the maximum 512 channels available in one DMX universe. Note that if independent control of a fixture is required, it must have its own DMX channels. Fixtures that are required to behave identically can share the same DMX address and channels. To add more fixtures or groups of fixtures when the above limit is reached, add a DMX universe and another daisy-chained link.

Tips for reliable data transmission

Use shielded twisted-pair cable designed for RS-485 devices: standard microphone cable cannot transmit control data reliably over long runs. 24 AWG cable is suitable for runs up to 300 meters (1000 ft.). Heavier gauge cable and/or an amplifier is recommended for longer runs. The pin-out on all connectors is pin 1 = shield, pin 2 = cold (-), and pin 3 = hot (+). Pins 4 and 5 in the 5-pin XLR connectors are not used in the fixture but are available for possible additional data signals as required by the DMX512-A standard. Standard pin-out is pin 4 = data 2 cold (-) and pin 5 = data 2 hot (+).

To split the link into branches, use a splitter, such as the Martin 4-Channel Opto-Isolated RS-485 Splitter/Amplifier. Terminate the link by installing a termination plug in the output socket of the last fixture. The termination plug, which is a male XLR plug with a 120-Ohm, 0.25-Watt resistor soldered between pins 2 and 3, “soaks up” the control signal so it does not reflect and cause interference. If a splitter is used, terminate each branch of the link.

Connecting the data link

To connect the fixture to data:

1. Connect the DMX data output from the controller to the closest fixture's male XLR DMX input connector.
2. Connect the DMX output of the fixture closest to the controller to the DMX input of the next fixture and continue connecting fixtures output to input. Terminate the last fixture on the link with a 120-Ohm resistor.

Fixture setup

This section explains the fixture settings and utilities that the user has access to via the control panel.

A complete map of the control menu structure can be found in 'Control menus' on page 30.

Settings are retained when the fixture is powered off.

Using the control menus

To access the control menus, press the MENU button. Navigate the menu structure using the ENTER, DOWN and UP buttons. Select any required menu option using the ENTER button. To return to the previous level in the menu structure without making a change, press the MENU button.

To exit the menus, press and hold the MENU button.

DMX addressing

The DMX address, also known as the start channel, is the first channel used to receive instructions from a DMX controller. The fixture can be controlled using signals sent by a DMX controller on twelve channels. Each DMX controlled fixture must have a DMX address set. For example, if a fixture has a DMX address of 10, then it uses channels 10, 11, 12, 13, 14, 15, 16, 17, 18, 19, 20 and 21. The following fixture in the DMX chain could then be set to a DMX address of 22.

For independent control, each fixture must be assigned its own control channels. Two fixtures of the same type may share the same address, if identical behavior is desired. Address sharing can be useful for diagnostic purposes and symmetric control, particularly when combined with the inverse pan and tilt options.

To set the fixture's DMX address:

1. In the control menu, select DMX ADDRESS and press ENTER to confirm. The present address will blink in the display.
2. Use the UP and DOWN buttons to select the address (1 to 512).
3. Once the address has been selected, press ENTER to set it (or press MENU to exit without saving any changes).

Show Mode (stand-alone operation)

The fixture will enter Show Mode and run stand-alone operation:

- if the fixture is not receiving a DMX signal and you enter the SHOW MODE menu in the control panel, or
- if the fixture is not receiving a DMX signal and the DMX STATE menu is set to SHOW MODE in the control panel (see 'DMX State – automatic Show Mode startup on page 21), or
- if you send a command on the fixture settings DMX channel to set the fixture to stand-alone operation.

Four pre-programmed stand-alone shows are available. To set the show that the fixture will run in Show Mode:

1. Select SHOW MODE and press ENTER to confirm. The currently selected show will blink in the display.
2. Use the DOWN and UP buttons to select Show 1, Show 2, Show 3 or Show 4.
3. Press ENTER to save your selection (or press MENU to exit without saving any changes).

Sound activation in Show Mode

Show Mode can be combined with sound activation. The fixture has a built-in microphone that can be used to trigger scene changes in sync with a music beat (music trig) when the fixture is running in Show Mode.

To enable sound activation:

1. Select SOUND STATE and press ENTER to confirm. The currently set mode will blink in the display.
2. Use the DOWN and UP buttons to select ON (sound activation enabled) or OFF (sound activation disabled).
3. Press ENTER to save your selection (or press MENU to exit without saving any changes).

To adjust the sensitivity of the sound activation microphone to match the volume of the music beat:

1. Select SOUND SENSE and press ENTER to confirm. The currently set sensitivity level will blink in the display.
2. Use the DOWN and UP buttons to change the sensitivity level from 0 ...100.
3. Press ENTER to save your selection (or press MENU to exit without saving any changes).

Dimming curves

Four dimming modes are available:

- MODE 1 LINEAR. The increase in light intensity appears to be linear as DMX value is increased.
- MODE 2 SQUARE LAW – light intensity control is finer at low levels and coarser at high levels.
- MODE 3 INVERSE SQUARE LAW – light intensity control is coarser at low levels and finer at high levels.
- MODE 4 S-CURVE – light intensity control is finer at low levels and high levels and coarser at medium levels.

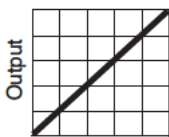

Optically linear

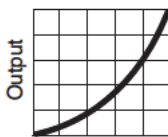

Square law

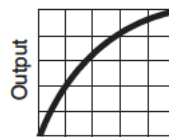

Inverse square law

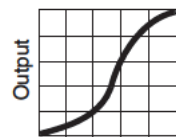

S-curve

To set the fixture's dimmer curve:

1. Select DIMMER CURVE and press ENTER to confirm. The mode that is currently active will blink in the display.
2. Use the DOWN and UP buttons to select Mode1, Mode 2, Mode 3 or Mode 4.
3. Press ENTER to save your selection (or press MENU to exit without saving any changes).

Pan/tilt inversion

The PAN INVERSE and TILT INVERSE menus can be used to reverse the direction of pan and tilt. These settings are useful for symmetrical effects with multiple fixtures, or when coordinating the movement of fixtures that are floor mounted and rigged upside down.

To adjust the pan inversion settings:

1. Select PAN INVERSE and press ENTER to confirm. The currently set mode will blink in the display.
2. Use the DOWN and UP buttons to select YES (pan inversion) or NO (normal) mode.
3. Press ENTER to save your selection (or press MENU to exit without saving any changes).

To adjust the tilt inversion settings:

1. Select TILT INVERSE and press ENTER to confirm. The currently set mode will blink in the display.
2. Use the DOWN and UP buttons to select the YES (tilt inversion) or NO (normal) mode.
3. Press ENTER to save your selection (or press MENU to exit without saving any changes).

Backlight

To turn the control panel display backlight on or off:

1. Select BACK LIGHT menu and press ENTER to confirm. The present mode will blink in the display.
2. Use the DOWN and UP buttons to select ON or OFF.
3. Press ENTER to save your selection (or press MENU to exit without saving any changes).

White balance adjustment

To adjust the fixture's white balance:

1. Select WHITE BALANCE and press ENTER to confirm.
2. Use the DOWN and UP buttons to select RED, GREEN or BLUE.
3. Once the color has been selected, press ENTER.
4. Use the DOWN and UP buttons to adjust the amount of that color (125~255) in the white balance mix.
5. Press ENTER to save your selection (or press MENU to exit without saving any changes).

Function delay

To reduce the risk of accidental activation, you can set a delay of up to 3 seconds before a DMX command will activate a function on the control settings DMX channel. To set the delay duration:

1. Select FUNCTION DELAY and press ENTER to confirm. The current delay setting will blink in the display.
2. Use the DOWN and UP buttons to select No Delay, 1S Delay, 2S Delay or 3S Delay.
3. Press ENTER to save your selection (or press MENU to exit without saving any changes).

DMX State – automatic Show Mode startup

The DMX STATE setting in the control menu determines how the fixture behaves when it is powered on but not receiving a DMX signal. You can set the fixture to enter Show Mode for stand-alone operation, to black out, or to hold the effect it was displaying when the DMX signal stopped.

To adjust the setting:

1. Select DMX STATE and press ENTER. The currently set option will blink in the display.
2. Use the DOWN and UP buttons to select SHOW MODE (fixture enters Show Mode), BLACKOUT (fixture blacks out) or HOLD (fixture shows the last effect it was displaying before the DMX signal stopped).
3. Press ENTER to save your selection (or press MENU to exit without saving any changes).

The fixture is set to BLACKOUT by default.

Manual test

Fixture functions can be tested or controlled manually:

1. Select MANUAL TEST and press ENTER.
2. Use the DOWN and UP buttons to select PAN, TILT, RED1, GREEN1, BLUE1, WHITE1...RED4, GREEN4, BLUE4, WHITE4, DIMMER or STROBE.
3. Once the mode has been selected, press ENTER.
4. Use the DOWN and UP button to change the value (0-255).
5. Press MENU to exit.

Auto test

To perform a complete test of all of the fixture functions:

1. Select AUTO TEST and press ENTER. The fixture will run a self-test routine.
2. Press MENU to exit the test.

Temperature

To check the onboard temperature of the fixture:

1. Select TEMP and press ENTER. The display will show the temperature of the unit.
2. Press MENU to exit.

Fixture time

To display the fixture's operating hours counter:

1. Select FIXTURE TIME and press ENTER. The display will show the number of hours the fixture has been in operation since manufacture.
2. Press MENU to exit.

Firmware version

To display the fixture's installed firmware (fixture software) version number:

1. Select FIRMWARE VERSION and press ENTER. The display will show the installed firmware version.
2. Press MENU to exit.

Pro defaults

PRO DEFAULTS lets you cancel any changes in fixture settings that have been made using the control panel and return the fixture to its original factory default settings. To restore the default settings:

1. Select PRO DEFAULTS and press ENTER. The display will blink.
2. Use the DOWN and UP buttons to select YES.
3. Press ENTER to restore the default settings (or press MENU to exit without saving any changes).

Reset

The fixture resets each time you power it on, but you can also reset the fixture manually. To carry out a manual reset:

1. Scroll to RESET and press ENTER to reset the fixture (or press MENU to exit without resetting).
2. A reset takes approx. 20 seconds. After this, the fixture returns to its state before the reset.

Head home position (offsets) adjustment

If the fixture head does not return to its home position, even after a reset, you can adjust the home position by defining offsets for pan and tilt. To make the adjustment:

1. In the menu structure, press and hold ENTER for at least 3 seconds to enter Offset mode.
2. Use the DOWN and UP buttons up to choose PAN OFFSET or TILT OFFSET. Press ENTER and the display will blink.

3. Use the DOWN and UP buttons to adjust the home position of the head on the pan or tilt axis.
4. Press ENTER to save your selection (or press MENU to exit without saving any changes).

DMX control of fixture settings

You can access the following functions from a DMX controller on the fixture settings DMX channel:

- You can reset the fixture.
- You can enable or disable blackout during pan and tilt movement. When enabled, the fixture blacks out when the head moves and lights up again as soon as the head stands still.

Effects and dimming can be optimized for speed or smoothness.

The fixture can be set to run in stand-alone operation. If set to stand-alone, the fixture will run the show selected in the SHOW MODE menu. If sound activation is enabled, it will run music trig.

You can reduce the risk of accidentally making a change on the fixture settings channel if you set a delay before these functions can be activated via DMX (see 'Function delay' on page 20).

Effects

See 'DMX protocol' on page 27 for a full list of the DMX channels and values required to control the different effects.

Pan and tilt

The fixture's head can be panned through 540° and tilted through 180°. Using the control menus it is possible to invert pan or tilt movement and enable or disable blackout during movement of the head.

Strobe effects

The strobe effects provide instant open and blackout, variable speed regular and random strobe.

Electronic dimming

Overall intensity can be adjusted 0-100% using electronic dimming. Four different dimming curves are available (see 'Dimming curves' on page 19).

Color control

Full RGBW color mixing is available.

You can also select from 33 Lee-referenced color presets and snap through the colors as if you were rotating a color wheel.

Maintenance



Warning! Read ‘Safety information’ on page 5 before servicing the fixture.

Refer any service operation not described in this user manual to a qualified service technician.

Disconnect the fixture from mains power before cleaning or servicing.

Service fixtures in an area where there is no risk of injury from failing parts, tools or other materials.

The user may carry out the service operations described in this manual. All other service operations must be carried out by an authorized Martin™ service technician. Do not try to repair the fixture yourself, as you may create a safety risk or cause damage that is not covered by the product warranty.

Installation, on-site service and maintenance can be provided worldwide by the Martin Professional™ Global Service organization and its approved agents, giving owners access to Martin’s expertise and product knowledge in a partnership that will ensure the highest level of performance throughout the product’s lifetime. Please contact Martin™ for details.

Cleaning

Excessive dust, smoke fluid, and particle buildup degrades performance, causes overheating and will damage the fixture. Damage caused by inadequate cleaning or maintenance is not covered by the product warranty.

The cleaning of external optical lenses must be carried out periodically to optimize light output. Cleaning schedules for lighting fixtures vary greatly depending on the operating environment. It is therefore impossible to specify precise cleaning intervals for the fixture. Environmental factors that may result in a need for frequent cleaning include:

- Use of smoke or fog machines.
- High airflow rates (near air conditioning vents, for example).
- Presence of cigarette smoke.
- Airborne dust (from stage effects, building structures and fittings or the natural environment at outdoor events, for example).

If one or more of these factors is present, inspect fixtures within their first 100 hours of operation to see whether cleaning is necessary. Check again at frequent intervals. This procedure will allow you to assess cleaning

requirements in your particular situation. If in doubt, consult your RUSH by Martin dealer about a suitable maintenance schedule.

Use gentle pressure only when cleaning, and work in a clean, well-lit area. Do not use any product that contains solvents or abrasives, as these can cause surface damage.

To clean the fixture:

1. Disconnect the fixture from power and allow it to cool for at least 10 minutes.
2. Vacuum or gently blow away dust and loose particles from the outside of the fixture and the air vents at the back and sides of the head and in the base with low-pressure compressed air.
3. Clean surfaces by wiping gently with a soft, clean lint-free cloth moistened with a weak detergent solution. Do not rub glass surfaces hard: lift particles off with a soft repeated press. Dry with a soft, clean, lint-free cloth or low-pressure compressed air. Remove stuck particles with an unscented tissue or cotton swab moistened with glass cleaner or distilled water.
4. Check that the fixture is dry before reapplying power.

Replacing the primary fuse

If the fixture is completely dead, the fixture's primary fuse F1 may have blown and it may be necessary to install a new fuse. This fuse is located in a fuseholder next to the MAINS IN and OUT sockets on the connections panel. See 'Fixture overview' on page 15.

If you need to replace a fuse:

1. Disconnect the fixture from power and allow it to cool for at least 10 minutes.
2. Unscrew the cap of the fuseholder and remove the fuse. Replace with a fuse of the same size and rating only.
3. Reinstall the fuseholder cap before reapplying power.

Service and repairs

There are no user serviceable parts inside the fixture. Do not open the housing.

Never try to repair the fixture by yourself as this may result in damage or malfunction and it may potentially void your product warranty. The equipment must only be serviced or repaired by an authorized RUSH by Martin service technician.

DMX protocol

| Channel | Value | Function |
|-----------|---------------------------------|--|
| 1 | | Electronic shutter effect |
| | 0 - 19 | Shutter closed |
| | 20 - 49 | Shutter open |
| | 50 - 64 | Strobe 1 (fast to slow) |
| | 65 - 69 | Shutter open |
| | 70 - 84 | Strobe 2: opening pulse (fast to slow) |
| | 85 - 89 | Shutter open |
| | 90 - 104 | Strobe 3: closing pulse (fast to slow) |
| | 105 - 109 | Shutter open |
| | 110 - 124 | Strobe 4: random strobe (fast to slow) |
| | 125 - 129 | Shutter open |
| | 130 - 144 | Strobe 5: random opening pulse (fast to slow) |
| | 145 - 149 | Shutter open |
| | 150 - 164 | Strobe 6: random closing pulse (fast to slow) |
| | 165 - 169 | Shutter open |
| | 170 - 184 | Strobe 7: burst pulse (fast to slow) |
| | 185 - 189 | Shutter open |
| | 190 - 204 | Strobe 8: random burst pulse (fast to slow) |
| | 205 - 209 | Shutter open |
| | 210 - 224 | Strobe 9: sine wave (fast to slow) |
| 225 - 229 | Shutter open | |
| 230 - 244 | Strobe 10: burst (fast to slow) | |
| 245 - 255 | Shutter open | |
| 2 | 0-255 | Dimmer 0-100% |
| 3 | 0-255 | Pan 0°-540° |
| 4 | 0-255 | Pan fine |
| 5 | 0-255 | Tilt 0°-180° |
| 6 | 0-255 | Tilt fine |
| 7 | | Fixture control settings |
| | 0-9 | No function |
| | 10-14 | Reset entire fixture |
| | 15-94 | No function |
| | 95-99 | Enable blackout during P/T movement |
| | 100-104 | No function |
| | 105-109 | Disable blackout during P/T movement |
| | 110-114 | Fast dimming, unrestricted effects speed |
| | 115-119 | No function |
| | 120-124 | Smooth dimming, slightly reduced effects speed |
| | 125-249 | Illuminate display |
| 250-255 | Stand-alone | |

| Channel | Value | Function |
|-----------|-----------------------------|-----------------------------|
| 8 | | Color wheel effect |
| | 0 - 9 | Open |
| | 10 - 14 | LEE 790 - Moroccan pink |
| | 15 - 19 | LEE 157 - Pink |
| | 20 - 24 | LEE 332 - Special rose pink |
| | 25 - 29 | LEE 328 - Follies pink |
| | 30 - 34 | LEE 345 - Fuchsia pink |
| | 35 - 39 | LEE 194 - Surprise pink |
| | 40 - 44 | LEE 181 - Congo Blue |
| | 45 - 49 | LEE 071 - Tokyo Blue |
| | 50 - 54 | LEE 120 - Deep Blue |
| | 55 - 59 | LEE 079 - Just Blue |
| | 60 - 64 | LEE 132 - Medium Blue |
| | 65 - 69 | LEE 200 - Double CT Blue |
| | 70 - 74 | LEE 161 - Slate Blue |
| | 75 - 79 | LEE 201 - Full CT Blue |
| | 80 - 84 | LEE 202 - Half CT Blue |
| | 85 - 89 | LEE 117 - Steel Blue |
| | 90 - 94 | LEE 353 - Lighter Blue |
| | 95 - 99 | LEE 118 - Light Blue |
| | 100 - 104 | LEE 116 - Medium Blue Green |
| | 105 - 109 | LEE 124 - Dark Green |
| | 110 - 114 | LEE 139 - Primary Green |
| | 115 - 119 | LEE 089 - Moss Green |
| | 120 - 124 | LEE 122 - Fern Green |
| | 125 - 129 | LEE 738 - JAS Green |
| | 130 - 134 | LEE 088 - Lime Green |
| | 135 - 139 | LEE 100 - Spring Yellow |
| | 140 - 144 | LEE 104 - Deep Amber |
| | 145 - 149 | LEE 179 - Chrome Orange |
| 150 - 154 | LEE 105 - Orange | |
| 155 - 159 | LEE 021 - Gold Amber | |
| 160 - 164 | LEE 778 - Millennium Gold | |
| 165 - 169 | LEE 135 - Deep Golden Amber | |
| 170 - 174 | LEE 164 - Flame Red | |
| 175 - 179 | Open | |

| Channel | Value | Function |
|---------------|-----------|---|
| 8 (contd.) | 180 - 201 | Color wheel rotation effect |
| | 202 - 207 | Clockwise, fast to slow |
| | 208 - 229 | Stop (this will stop wherever the color is at the time) |
| | 230 - 234 | Counter-clockwise, slow to fast |
| | | Open |
| | | Random color |
| | 235 - 239 | Fast |
| | 240 - 244 | Medium |
| | 245 - 249 | Slow |
| | 250 - 255 | Open |
| 9 | 0-255 | Red 0-100% |
| 10 | 0-255 | Green 0-100% |
| 11 | 0-255 | Blue 0-100% |
| 12 | 0-255 | White 0-100% |

Control menus

To access the control menus, press the MENU button. Use the UP and DOWN buttons to navigate the menus. Select any required menu option using the ENTER button. For more information, see 'Using the control menus' on page 17.

The factory default settings are shown in bold.

| Menu | Sub-menu | Explanation |
|----------------|-----------------|---|
| DMX Address | 1–512 | Fixture DMX address setting |
| Show Mode | Show 1...Show 4 | Show mode 1 to 4 |
| Dimmer Curve | Mode 1...Mode 4 | Select dimmer curve |
| DMX State | Show Mode | If no DMX signal, fixture enters Show Mode |
| | Blackout | If no DMX signal, fixture blacks out |
| | Hold | If no DMX signal, fixture continues its last effect |
| Sound State | On | Sound activation in Show Mode enabled |
| | Off | Sound activation in Show Mode disabled |
| Sound Sense | 0...100 | Microphone sensitivity for sound activation |
| Pan Inverse | Yes | Invert pan control |
| | No | Normal pan control |
| Tilt Inverse | Yes | Invert tilt control |
| | No | Normal tilt control |
| Back light | On | Control panel display backlight on |
| | Off | Display backlight off |
| Function Delay | No Delay | Set delay in seconds before functions on control settings DMX channel are activated |
| | 1s Delay | |
| | 2s Delay | |
| | 3s Delay | |

| | | |
|------------------|--------------------------|--------------------------------------|
| White Balance | Red (125...255) | Adjust white balance red mix |
| | Green (125...255) | Adjust white balance green mix |
| | Blue (125...255) | Adjust white balance blue mix |
| Manual Test | Pan (0...255) | Manual control of pan |
| | Tilt (0...255) | Manual control of tilt |
| | Red (0...255) | Manual control of red |
| | Green (0...255) | Manual control of green |
| | Blue (0...255) | Manual control of blue |
| | White (0...255) | Manual control of white |
| | Dimmer (0...255) | Manual control of dimmer |
| Strobe (0...255) | Manual control of strobe | |
| Auto test | | Automatic test of all functions |
| Temp. | | Temperature of onboard sensor |
| Fixture Time | | Fixture operating hours counter |
| Firmware Version | | Currently installed firmware version |
| PRO Defaults | Yes | Restore factory default settings |
| | No | Exit |
| Reset | | Reset fixture |

To access the Offset menu, press MENU to enter the menu structure and then press and hold ENTER for three seconds.

| Menu | Sub-menu | Explanation |
|--------|-------------|-------------|
| Offset | Pan offset | 127...-127 |
| | Tilt offset | 127...-127 |

Troubleshooting

This section describes a few common problems that may occur during operation and provides some suggestions for easy troubleshooting:

| Symptom | Potential cause | Remedies |
|--|--|---|
| No light from fixture, or fans not working. | Power supply issue such as blown fuse, faulty connector or damaged cable. | <p>Ensure that the mains supply is connected and supplying power to the fixture.</p> <p>Check all power connections and cables.</p> <p>Check and if necessary replace the fixture fuse.</p> |
| Fixture does not react to music beat. | <p>Sound activation disabled.</p> <p>Sound activation sensitivity too low for music source.</p> | <p>Ensure that fixture is not connected to a DMX signal.</p> <p>Check Show Mode and sound activation settings.</p> <p>Adjust sound activation microphone sensitivity.</p> <p>Tap microphone to check correct functionality. The fixture should react when in sound activation mode.</p> |
| One of the control channels is unresponsive or only responds intermittently. | <p>DMX setup or DMX link fault.</p> <p>Damaged step motor or cable connection between head and body.</p> | <p>See next section.</p> <p>Contact your RUSH by Martin authorized distributor or service center for assistance.</p> |

| Symptom | Potential cause | Remedies |
|--|---|--|
| Fixture does not respond to DMX control. | Fault in the DMX network due to connector or cable damaged, or incorrect DMX addressing, or potential interference from proximity to a high voltage installation. | <p>Ensure that fixture's DMX address matches address set on DMX control device.</p> <p>Check that fixture DMX LED is on, and if not, check all DMX cables and connections.</p> <p>Ensure that DMX link is terminated.</p> <p>Check that all components on DMX link use standard DMX polarity.</p> <p>Attempt to control the fixture with another DMX control device.</p> <p>Move or shield link if it is close to an unshielded high-voltage installation.</p> |

Specifications

Physical

Dimensions (LxWxH).....258 x 156 x 305 mm (10.1 x 6.1 x 12 in.)
 Weight5.7 kg (13 lbs.)

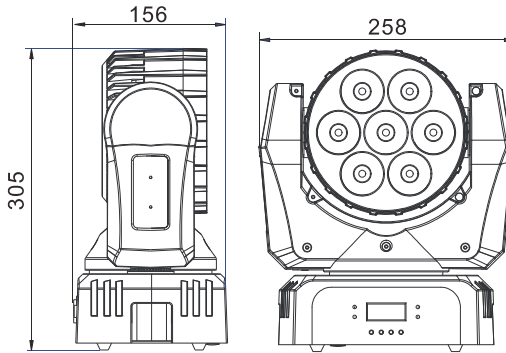

Dynamic Effects

Electronic color wheel effect.....33 colors plus white, rotation effect
 Color mixing.....RGBW, with white balance control
 Strobe effects Random, regular, variable speed
 Sound activation Adjustable microphone sensitivity
 Built-in shows 4 pre-programmed show modes
 Dimming Electronic 0-100%, four dimmer curves
 Pan 540°
 Tilt..... 180°
 Pan/tilt optionsInvert

Optics

Light source 7 x 10 W Cree MC-E RGBW LEDs

Control and Programming

Control options DMX, stand-alone (music trig, auto trig/show mode)
 DMX channels 12
 DMX compliance USITT DMX512/1990
 Interface..... Control panel with backlit display

Construction

Color Black
 IP rating IP 20

Installation

Mounting points Bracket for rigging clamp
Location Dry location only, must be fastened to surface or structure

Connections

AC power input Neutrik PowerCon
AC power throughput Neutrik PowerCon
DMX data in/out 3-pin & 5-pin locking XLR

Electrical

AC power 100-240 V nominal, 50/60 Hz
Power consumption 125 W
Fuse T6.3A
Power supply unit Auto-ranging electronic switch mode

Typical power and current

110 V, 60 Hz 125 W, 1.9 A
230 V, 50 Hz 121 W, 1.0 A
Measurements made at nominal voltage with all LEDs at full intensity. Allow for a deviation of +/- 10%.

Thermal

Cooling Forced air
Maximum ambient temperature (T_a max.) 40° C (104° F)
Minimum ambient temperature (T_a min.) 0° C (32° F)
Total heat dissipation* 430 BTU/hr.
**Calculated, +/- 10%, at full intensity, full white*

Approvals



EU safety EN 60598-2-17 (EN 60598-1), EN 62471, EN 62493
EU EMC EN 55015, EN 55103-1, EN 55103-2,
..... EN 61000-3-2, EN 61000-3-3, EN 61547
US safety UL 1573
US EMC FCC Part 15 Class A
Canadian safety CSA C22.2 No. 166
Canadian EMC ICES-003 Class A
Australia/NZ C-TICK N4241

Included Items

Power cable, 6 A, 18 AWG, 0.75 mm², UL- listed, H05VV-F, 1.5 m, without mains plug
Bracket for rigging clamp attachment

Accessories

Cables, 16 A, for connection to power in chains

| | |
|---|--------------|
| Power input cable, 14 AWG, SJT, 1.5 mm ² , H05VV-F, with PowerCon input connector, 3 m (9.8 ft.)..... | P/N 11541508 |
| Power relay cable, 14 AWG, SJT, 1.5 mm ² , H05VV-F, with PowerCon connectors, 1.4 m (4.6 ft.)..... | P/N 11541509 |
| Power relay cable, 14 AWG, SJT, 1.5 mm ² , H05VV-F, with PowerCon connectors, 2.25 m (7.4 ft.)..... | P/N 11541510 |
| Power relay cable, 14 AWG, SJT, 1.5 mm ² , H05VV-F, with PowerCon connectors, 3.25 m (10.7 ft.)..... | P/N 11541511 |

Power connectors

| | |
|---|--------------|
| Neutrik PowerCon NAC3FCA power input connector, cable mount, blue | P/N 05342804 |
| Neutrik PowerCon NAC3FCB power output connector, cable mount, light grey | P/N 05342805 |

Installation hardware

| | |
|--|--------------|
| Half-coupler clamp | P/N 91602005 |
| G-clamp | P/N 91602003 |
| Quick-trigger clamp | P/N 91602007 |
| Safety cable, safe working load 50 kg..... | P/N 91604003 |

Related Items

| | |
|---------------------------------|--------------|
| RUSH Software Uploader 1™ | P/N 91611399 |
|---------------------------------|--------------|

Ordering Information

| | |
|--|--------------|
| RUSH MH 2 Wash™ in cardboard box, EU model | P/N 90280020 |
| RUSH MH 2 Wash™ in cardboard box, US model | P/N 90280025 |

Specifications subject to change without notice. For latest product specifications, see www.martin.com



Disposing of this product

RUSH by Martin™ products are supplied in compliance with Directive 2012/19/EC of the European Parliament and of the Council of the European Union on WEEE (Waste Electrical and Electronic Equipment), where applicable. Help preserve the environment! Ensure that this product is recycled at the end of its life. Your supplier can give details of local arrangements for the disposal of RUSH by Martin products

RUSH™
by Martin®